



PROTECTOR[®] Glove Boxes

Controlled Atmosphere and Multi-Hazard



Protecting your
laboratory environment

LABCONCO

TABLE OF CONTENTS

Overview	1
Selection Guide	3
Protector Controlled Atmosphere Glove Boxes	
Introduction	4
Features & Benefits	5
Pressure Control Module & Purge/Fill Control Module.....	6
Purge/Fill Process	7
AtmosPure Regenerative Drying Train Features & Benefits	8
Controlled Atmosphere Glove Boxes	
Specifications	10
Ordering Information.....	11
Dimensional Data.....	11
Controlled Atmosphere Glove Boxes with AtmosPure Regenerative Drying Train	
Specifications	12
Ordering Information.....	13
Dimensional Data.....	13
Double Controlled Atmosphere Glove Boxes	
Specifications	14
Ordering Information	15
Dimensional Data.....	16
Accessories	16
Protector Multi-Hazard Glove Boxes	
Introduction	18
Features & Benefits	19
Multi-Hazard Glove Boxes	
Specifications	20
Ordering Information.....	21
Dimensional Data.....	21
Double Multi-Hazard Glove Boxes	
Specifications	22
Ordering Information.....	23
Dimensional Data.....	23
Protector Combination Glove Boxes	
Specifications	24
Ordering Information.....	25
Dimensional Data.....	26
Protector Multi-Hazard Glove Boxes Accessories	27
Glove Box Base Stands	28
Gloves, Sleeves & Hands.....	28

Overview

A glove box is a sealed enclosure in which all handling of materials inside the box is carried out through long, relatively impermeable gloves secured to ports in the walls of the enclosure. The operator's hands and forearms are placed in the gloves from the outside of the box so that the operator is able to manipulate items inside the box with relative freedom while viewing the operation through a window.

The purpose of a glove box is protection or isolation, which is provided by a physical barrier. Depending on the type of glove box, the physical barrier may be to isolate a sensitive material inside the box from environmental contamination or to protect the operator from hazardous materials being manipulated inside the box.

Controlled Atmosphere Glove Boxes

A controlled atmosphere glove box, sometimes called a "dry box," is an enclosure that maintains a leak-free environment so that experiments may be carried out under controlled conditions, such as in low levels of oxygen and moisture, with positive or negative pressure, or utilizing an inert gas. Controlled atmosphere glove boxes are widely used for air-sensitive inorganic, organic, organometallic and biochemical materials.

Multi-Hazard Glove Boxes

A multi-hazard glove box is an enclosure that protects the product inside the box from particulate contamination and protects the operator from potentially hazardous materials by filtration and a physical barrier. Applications for multi-hazard glove boxes include weighing reactive solids, loading capillary tubes for x-ray diffusion, and transfer of low level radioactive, carcinogenic and other hazardous materials.



Combination Glove Boxes

A combination glove box has the capability to handle both atmosphere-sensitive materials and hazardous substances. In the controlled atmosphere mode, the box can be pressurized and filled with an inert gas to achieve a leak-tight, inert atmosphere. Opening two internal valves converts the box to multi-hazard mode. Air entering and leaving the box passes through a filtration system to provide a particulate-free internal environment and protection for the user.

Protector® Glove Box Selection Criteria

Each Protector Glove Box consists of a gas-tight box fitted with a window, a pair of gloves and a transfer chamber with gas-tight door. The transfer chamber facilitates the introduction of apparatus with minimum compromise of the glove box atmosphere, particularly important with controlled atmosphere glove boxes.

Other features distinguish one type of glove box from another. For example, Protector Controlled Atmosphere Glove Boxes have inlet and outlet valves for both the main and transfer chambers so that inert atmospheres can be established and maintained. Since pressure control is critical, these boxes have built-in gauges for monitoring main and transfer chamber pressures. Protector Multi-Hazard Glove Boxes have a filtration and blower system to purify the air entering and leaving the cabinet and, depending on the application, may require ducting to the outside of the laboratory. An integral pressure gauge for monitoring the glove box pressure and filter loading is provided. When selecting a Protector Controlled Atmosphere, Multi-Hazard or Combination Glove Box, the following factors should be considered.

Materials of Construction

Protector Glove Boxes are available with two liner types: one-piece molded fiberglass and stainless steel. Both stainless steel and fiberglass are relatively impermeable compared to less favorable materials such as plastic, wood and composite board. Selection between fiberglass and stainless steel should be based on personal preference, corrosion-resistance and heat-resistance related to the operator's applications. The chart below compares the two liner materials.

LINER MATERIAL	STAIN RESISTANCE	MOISTURE RESISTANCE	CHEMICAL RESISTANCE	HEAT RESISTANCE	CLEANABILITY
One-Piece, Molded Fiberglass	Good	Excellent	Excellent	Very Good	Excellent (smooth finish)
Stainless Steel	Good	Excellent	Good resistance to a wide range, subject to attack by some acids	Excellent	Good (brushed finish)



Protector Fiberglass Multi-Hazard Glove Box



Protector Stainless Steel Controlled Atmosphere Glove Box



Protector Stainless Steel Combination Glove Box

Size

Protector Glove Boxes have interior widths of 35.5" and depths of 28" to accommodate a wide variety of apparatus and applications. Protector Stainless Steel Double Glove Boxes have twice the width and four glove ports suitable for two operators, multi-step experiments or large apparatus.

Gloves

The type of glove selected depends on the application. Protector Glove Boxes come standard with neoprene gloves. Neoprene gloves have high tensile strength and flexibility and are suitable for work requiring good sensitivity and dexterity. Gloves of other materials are offered as accessories for on-site installation. Butyl gloves provide a high degree of impermeability to air and water vapor, but swell when in contact with hydrocarbons. They resist oxygenated solvents and most oxidizing chemicals. Hypalon* gloves offer resistance to abrasion, ozone and oxidizing chemicals. They are soft and comfortable to use. Latex Gloves offer good dexterity but limited protection. When interior atmosphere control is not critical, accessory Neoprene Straight and Accordion Sleeves are available that may be used with Neoprene or Latex Hands.

Selection Guide

The Selection Guide that follows helps you select the appropriate Protector Glove Box and accessories for your application. For technical assistance in selecting the right glove box for your application, please call us at **800-821-5525** or **816-333-8811**.

* Hypalon® is a registered trademark of E.I. du Pont de Nemours and Company.

Selection Guide

APPLICATION/ MATERIAL	PROTECTOR GLOVE BOX	BUILT-IN OPTIONS	REQUIRED ACCESSORIES	OPTIONAL ACCESSORIES
Hydrophilic Chemicals, Chemical Compounding, Organic Synthesis, Electronic Component Assembly	Controlled Atmosphere	Main Chamber Pressure Control Module, Transfer Chamber Purge/Fill Control Module	Vacuum Pump, Glove Box Base Stand, Inert Gas	Vacuum and Gas Connection Kits, Interior Glove Port Cover, Exterior Glove Port Cover, Butyl Gloves, Hypalon Gloves, Interior Shelves
Organometallic Catalysis, Metabolic Research, Air-Sensitive Compounds, Inert Atmosphere for Processing Materials in Low Moisture and/or Low Oxygen Environments	Controlled Atmosphere with AtmosPure Regenerative Drying Train			
Pharmaceutical R&D/ Manufacturing, Biochemicals Particulate Radioisotopes, Particulate Chemical Carcinogens, Non-biohazardous Microorganisms & Biochemicals, Asbestos, Proteins & Enzymes, Crime Scene Evidence	Multi-Hazard		Secondary HEPA Exhaust Filter, Glove Box Base Stand	Interior Glove Port Cover, Exterior Glove Port Cover, Butyl Gloves, Hypalon Gloves, Neoprene Straight Sleeves, Neoprene Accordion Sleeves, Neoprene Hands, Latex Hands, Interior Shelves
Gaseous Chemical Carcinogens, Gaseous Radioisotopes	Multi-Hazard		Secondary Carbon Exhaust Filter, Glove Box Base Stand	
Combination of Hazardous Chemical and Controlled Atmosphere Work	Combination	Pressure Control Module, Purge/Fill Control Module	Vacuum Pump, Glove Box Base Stand, Inert Gas	Vacuum Connection Kit, Interior Glove Port Cover, Exterior Glove Port Cover, Butyl Gloves, Hypalon Gloves, Secondary HEPA or Carbon Exhaust Filter
Applications Involving Multi-Step Experiments, Work Involving Materials Or Equipment Longer than the Width of a Standard Glove Box	Double Stainless Steel Controlled Atmosphere or Multi-Hazard	Any option or accessory described above that fits your application.		

Controlled Atmosphere

Protector® Controlled Atmosphere Glove Boxes



Protector Controlled Atmosphere Glove Boxes provide a leak-tight environment for work with contamination-sensitive materials. Organometallic chemistry, lithium battery handling, hemoglobin research or other procedures using oxygen- or moisture-sensitive materials may be performed within these boxes.

Several design features work together to establish and maintain the glove box environment. A large transfer chamber permits materials to be loaded and unloaded from the main chamber without disturbing the integrity of its established environment. A system of four valves allows you to control gas input and vacuum of the main and transfer chambers. Each box has been factory tested with helium and found to have no detectable leaks greater than 1×10^{-6} cc/sec (31.55 cc/yr).

Protector Controlled Atmosphere Glove Boxes are available with a variety of built-in options:

- Manually-controlled valves (all models).
- Main Chamber Pressure Control Module.
- Transfer Chamber Purge/Fill Control Module.
- Liners of one-piece molded fiberglass or stainless steel.
- Domestic 115 volts, 60 Hz operation or international 230 volts, 50 Hz operation.
- AtmosPure Regenerative Drying Train for automatic oxygen and moisture removal from the main chamber.
- Double Stainless Steel Glove Boxes with twice the interior working width.
- Combination Glove Boxes for applications involving both hazardous chemicals and controlled atmospheres. See pages 24-26.

Full one year warranty on parts and labor.

Laminated safety glass window, 3/8" thick, has 10° angle to minimize glare and help reduce operator fatigue. Large viewing area provides maximum visibility. Contact Labconco about polycarbonate window.

One-piece molded fiberglass or stainless steel liner provides a smooth, durable surface that resists chemical corrosion and simplifies cleaning.

One-piece, molded neoprene gasket seals the glass to the liner and provides a leak-tight interior atmosphere.

Pressure relief bubbler, which mounts on the back of the box, helps protect against accidental over- or under-pressurization.

Comfortable, 8" diameter, epoxy-coated aluminum glove ports with neoprene gaskets and stainless steel clamps. Ports are double-grooved so that gloves may be changed with minimal disturbance to the integrity of the main chamber atmosphere.

Two interior electrical receptacles are separately controlled by individual switches on the control panel.

Easy access circuit breakers on the back of the box provide over current protection to interior and exterior receptacle circuits.

ETL-listed. All 115 volt, 60 Hz models without AtmosPure Regenerative Drying Train carry the ETL mark signifying that they are certified to UL 3101-1/61010-1* and CAN/CSA C22.2 No. 1010.1.**



Features & Benefits

One exterior electrical receptacle for vacuum pump operation is provided on the back.

30-watt fluorescent lamp provides interior lighting and is easily accessible from outside of the chamber.

Factory-tested with a helium mass spectrometer while pressurized with helium at 5 inches water gauge. Each box has no detectable leaks greater than 1×10^{-6} cc/sec (31.55 cc/yr).

Epoxy-coated steel front and end panels complement laboratory furniture.

Large transfer chamber allows quick transfer of materials and equipment between the laboratory and the box, while maintaining the established glove box environment.

Control switches for fluorescent lamp, interior and exterior electrical receptacles are conveniently located on the control panel.



Neoprene gloves, size 9 3/4, 30" long, are included. For critical operations, butyl or Hypalon gloves are available.



Pressure gauges enable the operator to monitor pressures in the glove box and transfer chamber.

CE mark. All 230 volt, 50 Hz models without AtmosPure Regenerative Drying Train conform to the CE (European Community) requirements for electrical safety and electromagnetic compatibility.

Space-saving inner and outer transfer chamber doors pivot upward, are counterbalanced and equipped with quick-latches for easy operation. Model Series 50600, 50700 and 50800 are made of 3/4" clear acrylic plastic for easy viewing. Model Series 50601, 50701 and 50801 are made of 11 gauge Type 304 stainless steel.

* Underwriters Laboratories (UL) 61010-1 (formerly 3101-1) Electrical Equipment for Laboratory Use specifies the general safety requirements for electrical equipment.

** Canadian Standards Association (CAN/CSA) Standard C22.2 No. 1010.1-92 Safety Requirements for Electrical Equipment for Measurement, Control and Laboratory Use.

Features & Benefits

In addition to the features and benefits found on Model Series 50600 and 50601, Model Series 50700 and 50701 have a **Main Chamber Pressure Control Module** with the following features:

- Automatic pressure controller monitors and controls glove box pressure. It allows the operator to establish an operating pressure range by setting upper and lower pressure limits within -6" to +6" water gauge. Range is indicated on the LED display.
- Bright LED light indicates the actual pressure, moving up or down the range as pressure increases or decreases.
- Two buttons allow the operator to increase or decrease operating pressure at any time.
- Audible alarm sounds and an indicator illuminates when pressure exceeds +6" water gauge or drops below -6" water gauge.
- Alarm reset button mutes the alarm.
- Pressure control foot pedal allows the operator to increase or decrease operating pressure without removing a hand from the box to make adjustments. It can also be used to momentarily adjust the glove box to negative pressure, allowing easy insertion or removal of hands from the box.

In addition to the features and benefits found on Model Series 50700 and 50701, Model Series 50800 and 50801 have a **Transfer Chamber Purge/Fill Control Module** with the following features:

- Purge/fill controller automatically regulates evacuation and backfill of the transfer chamber. It enables the operator to select the number of purge/fill cycles, the level of vacuum achieved at each purge cycle and the backfill gas source. The operator may select either "manual mode" for purging or filling or "auto sequencing," which starts or cancels the automatic purge/fill sequence.
- Bright LED display indicates the number and countdown of cycles, status of each cycle (purging or filling), and the end of the purge/fill cycle when the inner or outer door may be opened.



Pressure Control Foot Pedal



Pressure Control Module



Purge/Fill Control Module

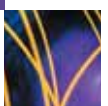

The Purge/Fill Process

The number of purge/fill cycles is variable. Depending on user preference, up to four cycles or up to 30 inches of mercury vacuum can be selected. Once the number of cycles, gas source and vacuum are selected, auto sequencing can begin with a touch of a button. The cycles and whether the transfer chamber is purging or filling are indicated on the panel by green indicator lights. The sequence is finished when the green indicator light marked "End" appears. The outer and inner doors may be safely opened at this time.

At right is an example of a purge/fill sequence:

- 1. Purge.** The vacuum pump pulls the ambient air from the transfer chamber and the air is vented to the outside or released into the room.

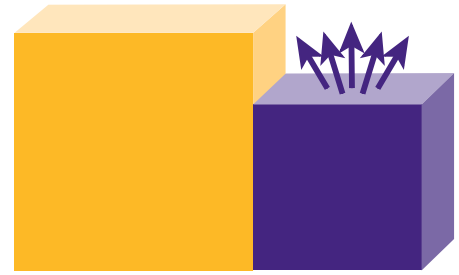

- 2. Fill.** The transfer chamber is filled with an inert gas such as nitrogen or argon, creating a mix.



- 3. Purge.** The mixed atmosphere is purged from the chamber and is vented to the outside or released into the room.

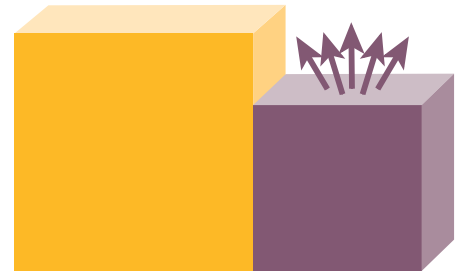

- 4. Fill.** The chamber is filled with the inert gas.



- 5. Purge.** The inert gas with a trace of ambient air is pulled from the chamber and vented to the outside or released into the room.

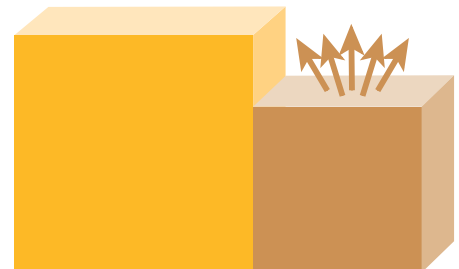

- 6. Fill.** On the last cycle, the chamber is filled with the inert gas; or the transfer chamber is filled from the established atmosphere in the box to ensure similar conditions.



AtmosPure® Regenerative Drying Train Built-In Accessory

The AtmosPure Regenerative Drying Train produces and maintains inert atmosphere for processing materials sensitive to moisture and/or oxygen by recirculating an inert gas, such as argon, helium or nitrogen, inside the main chamber. This self-contained automatic system includes factory-installed gas purifier, blower and manually-initiated automatic regenerator. The AtmosPure maintains a low moisture and low oxygen environment in the glove box by continuously circulating the main chamber atmosphere through the gas purifier, removing moisture and oxygen. This recirculation compensates for contamination from sources, such as permeation through gloves and insertion of contaminated materials into the box.

The gas purifier contains a moisture adsorbent and an oxygen scavenger. The adsorbent is a molecular sieve that removes water vapor from the inert gas that passes through it. The oxygen scavenger is a copper catalyst that removes oxygen from the gas that passes through it. When the system becomes saturated, the regeneration cycle is easily initiated. Depending on the application and frequency of use, regeneration may be necessary only once every month.

The AtmosPure Regenerative Drying Train is offered as a built-in option on any Protector Fiberglass or Stainless Steel Controlled Atmosphere Glove Box. See pages 12-13 for ordering information and dimensions.

FEATURES AND BENEFITS

Gas Purifier

Attains a glove box atmosphere of <5 ppm water and <1 ppm oxygen.

These levels are essential for many moisture and oxygen sensitive applications.

Large volume molecular sieve and copper catalyst column requires infrequent regeneration. Theoretical capacity is 660 grams H₂O and 5 liters O₂ at standard temperature and pressure (STP).

The 6 CFM blower ensures complete flow of box atmosphere through the purifier. The blower and return air port are located on opposing sides and corners allowing complete circulation throughout the box and preventing a "short circuit" loop. The result is more efficient oxygen and moisture level control.

Regenerator

Inert gas purge flow display ensures safe operation and complete regeneration. The operator knows at a glance if inert gas flow is sufficient before regeneration begins. Based on the reading, the operator can adjust the gas flow rate before starting the regeneration cycle.

The control module mounted above the transfer chamber includes easy-to-understand instructions. A digital timer and lights indicate each step and the cycle time expired.

The fully automatic regenerator allows the user to push one button and walk away. The cycle proceeds without constant monitoring allowing regeneration when the laboratory is unoccupied.

For greater user flexibility, regeneration steps can be manually reset or cancelled at any time during the cycle. In addition, any step can be manually initiated if desired.

The system automatically compensates for power outages. If the system is in the heat or purge stage and the failure is less than ten minutes, the system starts where it was interrupted. If the outage is longer than ten minutes, the system will reset and start over. This feature is important since the system can cool considerably in ten minutes resulting in an incomplete regeneration. The vacuum step will resume where it left off in the event of a power interruption of any duration.

Cycle step times are factory set for ease of operation and complete regeneration.

Cycle times are flexible and may be reprogrammed by the operator to meet specific applications.

The modular heater assembly lifts out should service ever be required.

The vacuum release switch vents pressure from the column after regeneration, preventing decompression of the box interior.



Protector Fiberglass Controlled Atmosphere Glove Box with AtmosPure Regenerative Drying Train



Gas Purifier

AtmosPure® Regenerative Drying Train Steps in Regeneration

1. Manually close both isolation valves.

START

2. Press "START/RESET" button to initiate the two minute inert gas/hydrogen mixture purge. Check the gas purge flow display to ensure adequate gas flow. Turn the vacuum pump on.

HEAT

3. Molecular sieve and copper catalyst column automatically heats for

three hours to evaporate moisture. "HEAT" indicator green light is on.

PURGE

4. Molecular sieve and copper catalyst column is automatically purged with inert gas/hydrogen mixture for one hour. Heat and the flowing gas drive the moisture from the molecular sieve. Hydrogen combines with oxygen in the copper catalyst to form water which is expelled (an oxidation/reduction reaction). "PURGE" indicator green light is on.

VACUUM

5. The vacuum pump continuously purges the column of residual moisture and oxygen until manually shut off. For complete regeneration, the vacuum cycle should continue for at least eight hours. "VAC." indicator green light is on.

VACUUM RELEASE

6. Turn the vacuum pump off. Press "VAC.REL." button momentarily to release vacuum. Open both isolation valves. Regeneration is complete.

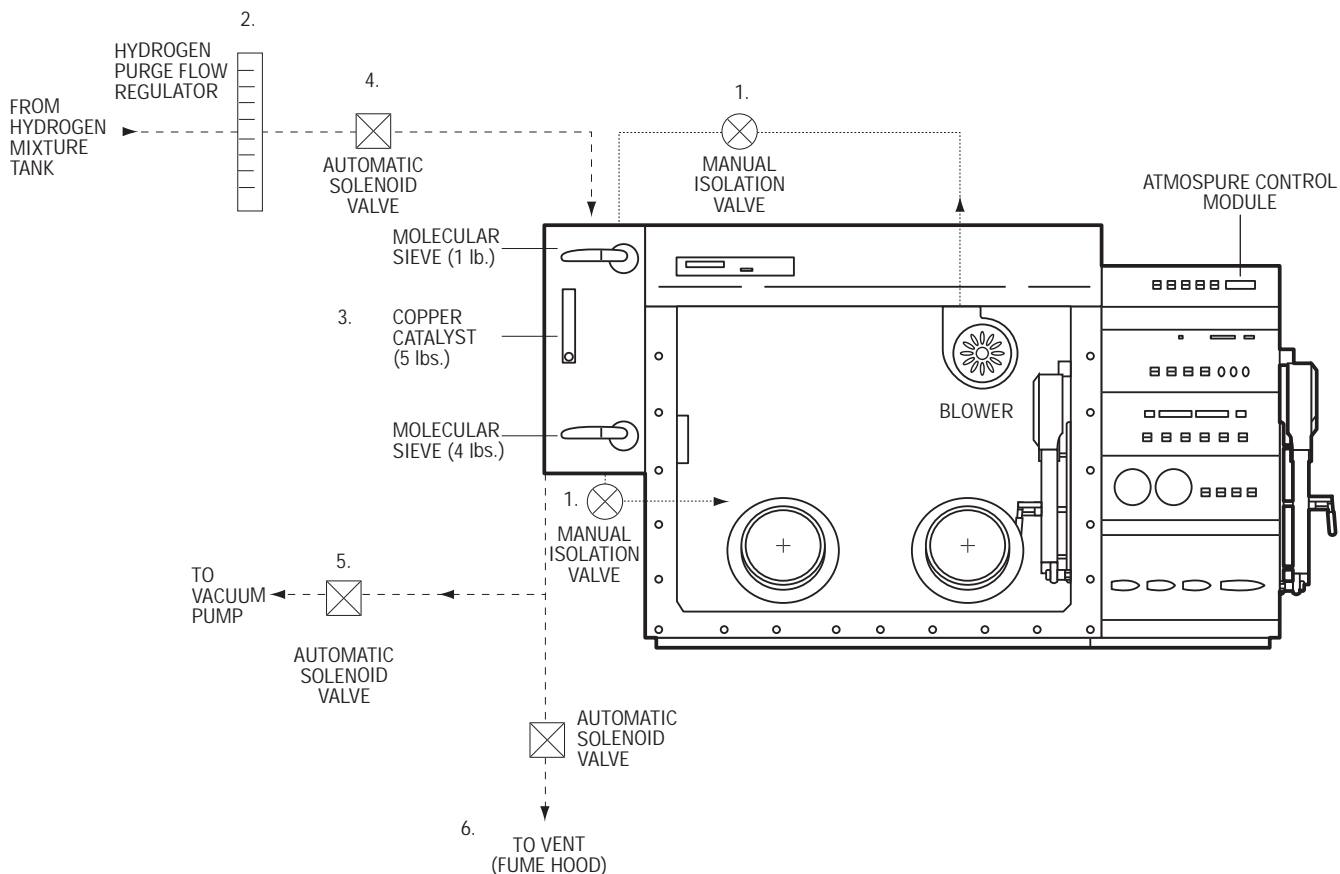
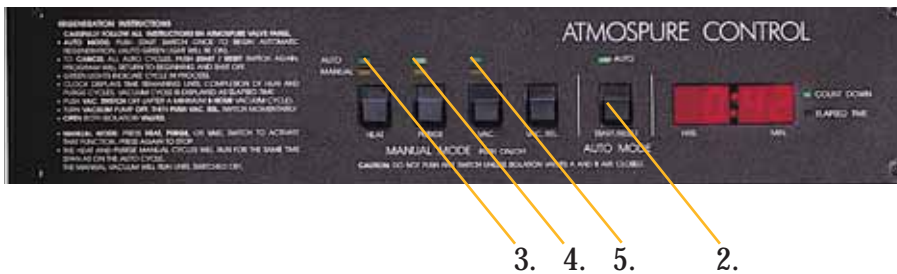

Protector® Controlled Atmosphere Glove Boxes



All models feature:

- Laminated safety glass window, 3/8" thick, with 10° angle and viewing area 36" w x 27.63" h.
- 12 gauge steel window frame with one-piece molded neoprene dual seal gasket.
- Two interior electrical receptacles with circuit breakers on the back of the box.
- Pressure relief bubbler. **Installation to back of box is required.**
- One pair of neoprene gloves, size 9 3/4, 0.015 gauge, 30" long, with stainless steel clamps.
- Two 8" ID, epoxy-coated aluminum, double-grooved glove ports mounted 17" apart, with neoprene gaskets.
- 30-watt fluorescent lamp.
- Dry-powder epoxy-coated, 18 and 20 gauge steel exterior panels.
- No detectable leaks greater than 1×10^{-6} cc/sec (31.55 cc/year) when factory-tested while pressurized with helium at 5" water gauge.
- Transfer chamber, interior dimensions 11" w x 20" d x 13" h, with counterbalanced inner and outer doors with quick-latches. Doors pivot upward to open.
- Control panel with main and transfer chamber analog pressure gauges; four valves to manually control gas input and vacuum of main and transfer chambers; and control switches for fluorescent

- lamp, left and right interior receptacles and rear exterior receptacle.
- 3/8" OD main chamber gas inlet and outlet (vacuum) connections, 3/8" OD transfer chamber inlet connection and 7/8" OD transfer chamber outlet (vacuum) connection.

All models conform to the following regulations and standards:

- UL 3101-1/61010-1
- CAN/CSA C22.2 No. 1010.1
- CE Conformity Marking (230 volt models)

Fiberglass Models feature:

- One-piece molded fiberglass liner.
- Clear 3/4" thick acrylic inner and outer transfer chamber doors.

Stainless Steel Models feature:

- Type 304 stainless steel liner.
- Type 304 stainless steel inner and outer transfer chamber doors.

Models with Pressure Control Module and Foot Pedal feature:

- Pressure Control Module that automatically monitors and controls main chamber pressure.
- Switches for high/low pressure limits and alarm reset.
- LED display to indicate range setting from -6" to +6" water gauge and actual pressure.

- Audible/visual alarm that alerts when pressure is outside of set range.
- Alarm reset to mute the audible alarm.
- Foot pedal control with 8' cable for hands-free adjustment of main chamber pressure.

Models with Purge/Fill Control Module feature:

- Purge/Fill Control Module to automatically control evacuation and backfill of transfer chamber.
- Switches for selection of number of purge/fill sequences, level of vacuum achieved at each purge cycle, and choice of backfill source.
- LED display to indicate number of purge/fill cycles selected and countdown of cycles, status of cycle (purging or filling), and source of purge/fill cycles.

All models require (not included):

- **Base Stand.** See page 28.
- **Vacuum Pump.** See page 17.
- **Inert Gas.** Contact your compressed gas supplier.
- **Vacuum and Gas Connection Kit.** See page 17.

Optional accessories for on-site installation include:

- **Drying Trains.** See page 17.
- **Exterior and Interior Glove Port Covers.** See page 17.
- **Interior Shelves.** See page 17.
- **Neoprene, Butyl and Hypalon Gloves.** See page 28.

Contact Labconco at **800-821-5525** or **816-333-8811** for ordering information on RS-232 ports, moisture/oxygen monitors, left side doors, interior hose connections, additional electrical receptacles, polycarbonate windows, stainless steel transfer trays and mini transfer chambers.



Protector® Controlled Atmosphere Glove Boxes

Ordering Information & Dimensional Data

CATALOG NUMBER	LINER MATERIAL	PRESSURE CONTROL MODULE & FOOT PEDAL	PURGE/FILL CONTROL MODULE	ELECTRICAL REQUIREMENTS	6' POWER CORD & PLUG	INTERIOR RECEPTACLES COMBINED RATING	EXTERIOR RECEPTACLE RATING	SHIPPING WEIGHT LBS./KG
5060000	Fiberglass	No	No	115 volts, 60 Hz, 20 amps	Yes	6 amps	9 amps	500/227
5060002*	Fiberglass	No	No	230 volts, 50 Hz, 10 amps	No plug	4 amps	6 amps	500/227
5060100	Stainless Steel	No	No	115 volts, 60 Hz, 20 amps	Yes	6 amps	9 amps	650/295
5060102*	Stainless Steel	No	No	230 volts, 50 Hz, 10 amps	No plug	4 amps	6 amps	650/295
5070000	Fiberglass	Yes	No	115 volts, 60 Hz, 20 amps	Yes	6 amps	9 amps	503/228
5070002*	Fiberglass	Yes	No	230 volts, 50 Hz, 10 amps	No plug	4 amps	6 amps	503/228
5070100	Stainless Steel	Yes	No	115 volts, 60 Hz, 20 amps	Yes	6 amps	9 amps	653/296
5070102*	Stainless Steel	Yes	No	230 volts, 50 Hz, 10 amps	No plug	4 amps	6 amps	653/296
5080000	Fiberglass	Yes	Yes	115 volts, 60 Hz, 20 amps	Yes	6 amps	9 amps	505/229
5080002*	Fiberglass	Yes	Yes	230 volts, 50 Hz, 10 amps	No plug	4 amps	6 amps	505/229
5080100	Stainless Steel	Yes	Yes	115 volts, 60 Hz, 20 amps	Yes	6 amps	9 amps	655/297
5080102*	Stainless Steel	Yes	Yes	230 volts, 50 Hz, 10 amps	No plug	4 amps	6 amps	655/297

* International electrical configuration

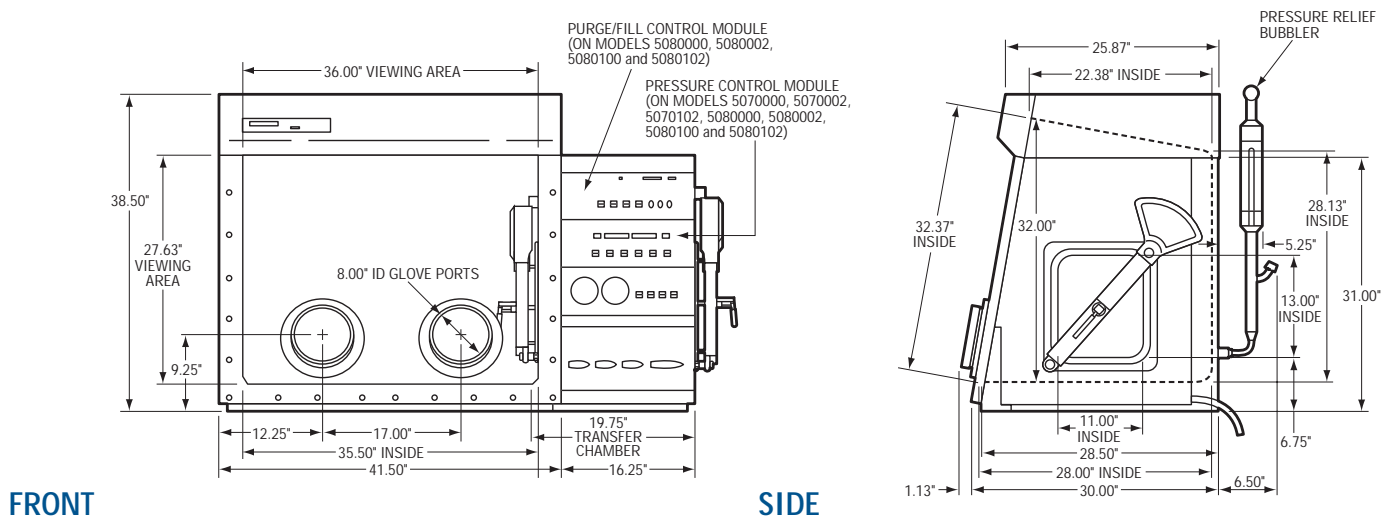
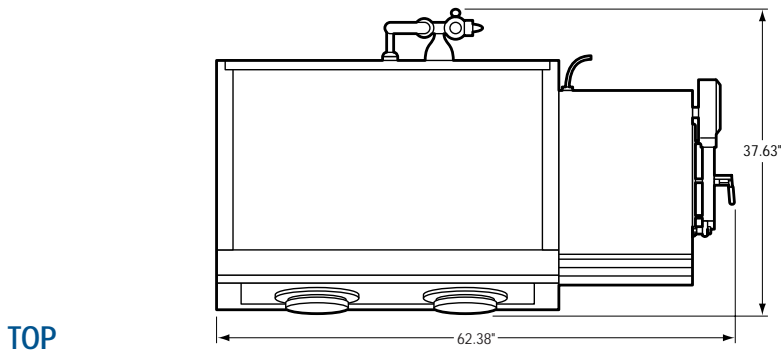

Protector® Controlled Atmosphere Glove Boxes with AtmosPure® Regenerative Drying Train

All models feature:

- Laminated safety glass window, 3/8" thick, with 10° angle and viewing area 36" w x 27.63" h.
- 12 gauge steel window frame with one-piece molded neoprene dual seal gasket.
- Two interior electrical receptacles with circuit breakers on the back of the box.
- Pressure relief bubbler. **Installation to back of box is required.**
- One pair of neoprene gloves, size 9 3/4, 0.015 gauge, 30" long, with stainless steel clamps.
- Two 8" ID, epoxy-coated aluminum, double-grooved glove ports mounted 17" apart, with neoprene gaskets.
- 30-watt fluorescent lamp.
- Dry-powder epoxy-coated, 18 and 20 gauge steel exterior panels.
- No detectable leaks greater than 1×10^{-6} cc/sec (31.55 cc/year) when factory-tested while pressurized with helium at 5" water gauge.
- Transfer chamber, interior dimensions 11" w x 20" d x 13" h, with counterbalanced inner and outer doors with quick-latches. Doors pivot upward to open.
- Control panel with glove box and transfer chamber pressure analog gauges; four valves to manually control gas input and exhaust of glove box and transfer chamber; and control switches for fluorescent lamp,

left and right interior receptacles and rear exterior receptacle.

- Gas purifier with insulated epoxy-coated steel housing mounted on the left side of the box. Purifier includes molecular sieve and copper catalyst, a hydrogen purge flow rate display, a heating element and two isolation valves.
- Interior-mounted, fractional hp motor/blower that delivers 6 CFM of airflow.
- Inlet port located in the center left interior.
- AtmosPure Control Module with switches and green indicator lights for manual control of heat, purge, vacuum and vacuum release; and a start/reset switch with green indicator light to initiate or reset the automatic regeneration cycle.
- LED for display of hours and minutes of time remaining until completion of heat and purge cycles and elapsed time of vacuum cycle.
- 3/8" OD glove box gas inlet connection, 3/8" OD glove box outlet (vacuum) connection, 3/8" OD transfer chamber inlet connection and 7/8" OD transfer chamber outlet (vacuum) connection.
- Separate 8' power cord and plug for drying train. 230 volt models without plug.

Fiberglass Models feature:

- One-piece molded fiberglass liner.
- Clear acrylic plastic inner and outer transfer chamber doors.

Stainless Steel Models feature:

- Type 304 stainless steel liner.
- Type 304 stainless steel inner and outer transfer chamber doors.

Models with Pressure Control Module and Foot Pedal feature:

- Pressure Control Module that automatically monitors and controls glove box pressure.
- Switches for high/low pressure limits and alarm reset.
- LED display to indicate range setting from -6" to +6" water gauge and actual pressure.
- Audible/visual alarm that alerts when pressure is outside of set range.
- Alarm reset to mute the audible alarm.
- Foot pedal control with 8' cable for hands-free adjustment of glove box pressure.

Models with Purge/Fill Control Module feature:

- Purge/Fill Control Module to automatically control evacuation and backfill of transfer chamber.
- Switches for selection of number of purge/fill sequences, level of vacuum achieved at each purge cycle, and choice of backfill source.
- LED display to indicate number of purge/fill cycles selected and countdown of cycles, status of cycle (purging or filling), and source of purge/fill cycles.

All models require (not included):

- **Base Stand.** See page 28.
- **Vacuum Pump.** See page 17.
- **Inert Gas.** Contact your compressed gas supplier.
- **Exhaust Source.** Contact Labconco.
- **Vacuum and Gas Connection Kit.** See page 17.



Optional accessories for on-site installation include:

- **Drying Trains.** See page 17.
- **Exterior and Interior Glove Port Covers.** See page 17.
- **Interior Shelves.** See page 17.
- **Neoprene, Butyl and Hypalon Gloves.** See page 28.

Contact Labconco at **800-821-5525** or **816-333-8811** for ordering information on RS-232 ports, moisture/oxygen monitors, left side doors, interior hose connections, additional electrical receptacles, polycarbonate windows, stainless steel transfer trays and mini transfer chambers.

Protector® Controlled Atmosphere Glove Boxes with AtmosPure™ Regenerative Drying Train

Ordering Information & Dimensional Data

CATALOG NUMBER	LINER MATERIAL	PRESSURE CONTROL MODULE & FOOT PEDAL	PURGE/FILL CONTROL MODULE	ELECTRICAL REQUIREMENTS	6' POWER CORD & PLUG	INTERIOR RECEPTACLES COMBINED RATING	EXTERIOR RECEPTACLE RATING	SHIPPING WEIGHT LBS./KG
50600009147	Fiberglass	No	No	115 volts, 60 Hz, 24 amps	Yes	6 amps	9 amps	540/245
50600029147*	Fiberglass	No	No	230 volts, 50 Hz, 12 amps	No plug	4 amps	6 amps	540/245
50601009147	Stainless Steel	No	No	115 volts, 60 Hz, 24 amps	Yes	6 amps	9 amps	690/313
50601029147*	Stainless Steel	No	No	230 volts, 50 Hz, 12 amps	No plug	4 amps	6 amps	690/313
50700009147	Fiberglass	Yes	No	115 volts, 60 Hz, 24 amps	Yes	6 amps	9 amps	543/246
50700029147*	Fiberglass	Yes	No	230 volts, 50 Hz, 12 amps	No plug	4 amps	6 amps	543/246
50701009147	Stainless Steel	Yes	No	115 volts, 60 Hz, 24 amps	Yes	6 amps	9 amps	693/314
50701029147*	Stainless Steel	Yes	No	230 volts, 50 Hz, 12 amps	No plug	4 amps	6 amps	693/314
50800009147	Fiberglass	Yes	Yes	115 volts, 60 Hz, 24 amps	Yes	6 amps	9 amps	545/247
50800029147*	Fiberglass	Yes	Yes	230 volts, 50 Hz, 12 amps	No plug	4 amps	6 amps	545/247
50801009147	Stainless Steel	Yes	Yes	115 volts, 60 Hz, 24 amps	Yes	6 amps	9 amps	695/315
50801029147*	Stainless Steel	Yes	Yes	230 volts, 50 Hz, 12 amps	No plug	4 amps	6 amps	695/315

* International electrical configuration

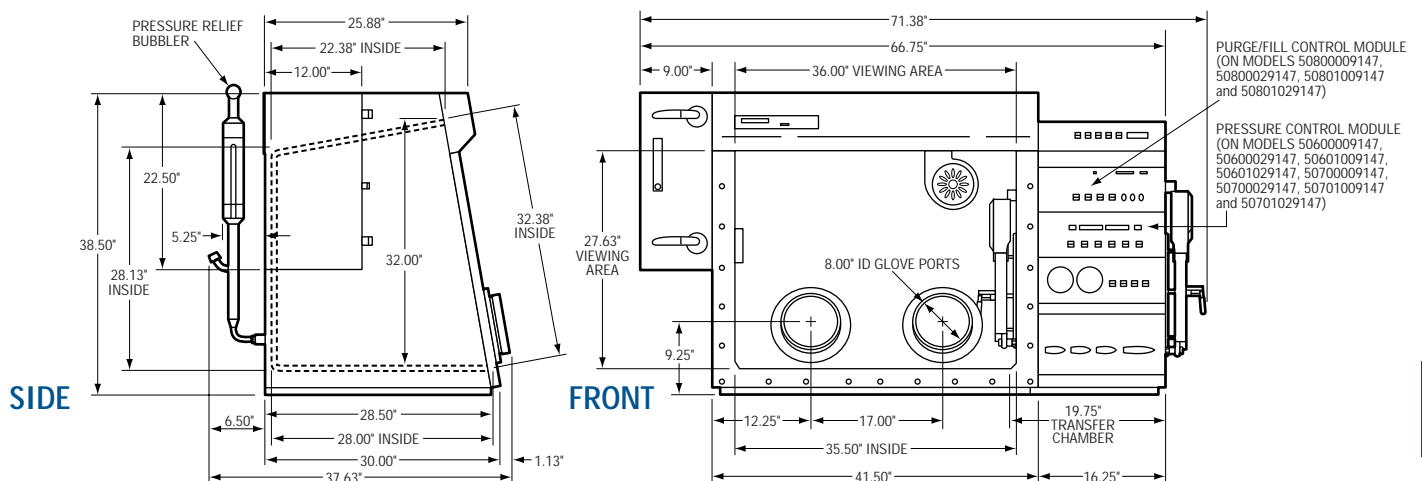

Protector® Double Controlled Atmosphere Glove Boxes

All models feature:

- Two Type 304 stainless steel liners connected by 9.34" wide, Type 304 stainless steel elevated bridge.
- Two laminated safety glass windows, 3/8" thick, each with 10° angle and viewing area 36" w x 27.63" h.
- Two 12 gauge steel window frames with one-piece molded neoprene dual seal gaskets.
- Four interior electrical receptacles with circuit breakers on the back of the box: two located on either side and two located along the back wall of the elevated bridge.
- Pressure relief bubbler. **Installation to back of box is required.**
- Two pairs of neoprene gloves, size 9 3/4, 0.015 gauge, 30" long, with stainless steel clamps.
- Two pairs of 8" ID, epoxy-coated aluminum, double-grooved glove ports mounted 17" apart, with neoprene gaskets.
- Two 30-watt fluorescent lamps.
- Dry-powder epoxy-coated, 18 and 20 gauge steel exterior panels.
- No detectable leaks greater than 1×10^{-6} cc/sec (31.55 cc/year) when factory-tested while pressurized with helium at 5" water gauge.
- Transfer chamber, interior dimensions 11" w x 20" d x 13" h, with counterbalanced inner and outer type 304 stainless steel doors with quick-latches. Doors pivot upward to open.
- Control panel with main and transfer chamber pressure analog gauges; four valves to manually control gas input and vacuum of main and transfer chambers; and control switches for fluorescent lamp, left and right interior receptacles and rear exterior receptacle.
- 3/8" OD glove box gas inlet and outlet (vacuum) connections, 3/8" OD transfer chamber inlet

connection and 7/8" OD transfer chamber outlet (vacuum) connection.

Models with Pressure Control Module and Foot Pedal feature:

- Pressure Control Module that automatically monitors and controls glove box pressure.
- Switches for high/low pressure limits and alarm reset.
- LED display to indicate range setting from -6" to +6" water gauge and actual pressure.
- Audible/visual alarm that alerts when pressure is outside of set range.
- Alarm reset to mute the audible alarm.
- Foot pedal control with 8' cable for hands-free adjustment of main chamber pressure.

All models without AtmosPure Regenerative Drying Train feature:

- UL 3101-1/61010-1
- CAN/CSA C22.2 No. 1010.1
- CE Conformity Marking (230 volt models)



Models with Purge/Fill Control Module feature:

- Purge/Fill Control Module to automatically control evacuation and backfill of transfer chamber.
- Switches for selection of number of purge/fill sequences, level of vacuum achieved at each purge cycle, and choice of backfill source.
- LED display to indicate number of purge/fill cycles selected and countdown of cycles, status of cycle (purging or filling), and source of purge/fill cycles.

Models with AtmosPure Regenerative Drying Train feature:

- Control panel with main and transfer chamber pressure analog gauges; four valves to manually control gas input and exhaust of main and transfer chambers; and control switches for fluorescent lamp, left and right interior receptacles and rear exterior receptacle.

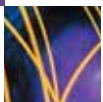

- Gas purifier with insulated epoxy-coated steel housing mounted on the left side of the box. Purifier includes molecular sieve and copper catalyst, an inert gas/hydrogen purge flow rate display, a heating element and two isolation valves.
- Interior-mounted, fractional hp motor/blower that delivers 6 CFM of airflow.
- Inlet port located in the center left interior.
- AtmosPure Control Module with switches and green indicator lights for manual control of heat, purge, vacuum and vacuum release; and a start/reset switch with green

indicator light to initiate or reset the automatic regeneration cycle.

- LED for display of hours and minutes of time remaining until completion of heat and purge cycles and elapsed time of vacuum cycle.
- Separate 8' power cord and plug for drying train. 230 volt models without plug.

All models require (not included):

- **Base Stand.** See page 28.
- **Vacuum Pump.** See page 17.
- **Inert Gas.** Contact your compressed gas supplier.
- **Vacuum and Gas Connection Kit.** See page 17.

Optional accessories for on-site installation include:

- **Drying Trains.** See page 17.
- **Exterior and Interior Glove Port Covers.** See page 17.
- **Interior Shelves.** See page 17.
- **Neoprene, Butyl and Hypalon Gloves.** See page 28.

Contact Labconco at **800-821-5525** or **816-333-8811** for ordering information on RS-232 ports, moisture/oxygen monitors, ultraviolet lights, left side doors, interior hose connections, additional electrical receptacles, polycarbonate windows, stainless steel transfer trays and mini transfer chambers.

Protector® Double Controlled Atmosphere Glove Boxes

Ordering Information

CATALOG NUMBER	PRESSURE CONTROL MODULE & FOOT PEDAL	PURGE/FILL CONTROL MODULE	ATMOSPURE REGENRATIVE DRYING TRAIN	ELECTRICAL REQUIREMENTS	(2) 6' POWER CORDS & PLUGS	INTERIOR RECEPTACLES COMBINED RATING	EXTERIOR RECEPTACLE RATING	SHIPPING WEIGHT LBS./KG
5060120	No	No	No	115 volts, 60 Hz, 20 amps 115 volts, 60 Hz, 15 amps	Yes Yes	5 amps 15 amps	9 amps N/A	900/408
5060122*	No	No	No	230 volts, 50 Hz, 10 amps 230 volts, 50 Hz, 10 amps	No plug No plug	9 amps** 10 amps	9 amps** N/A	900/408
50601209147	No	No	Yes	115 volts, 60 Hz, 20 amps 115 volts, 60 Hz, 15 amps	Yes Yes	5 amps 15 amps	9 amps N/A	900/408
50601229147*	No	No	Yes	230 volts, 50 Hz, 10 amps 230 volts, 50 Hz, 10 amps	No plug No plug	9 amps* 10 amps	9 amps** N/A	900/408
5070120	Yes	No	No	115 volts, 60 Hz, 20 amps 115 volts, 60 Hz, 15 amps	Yes Yes	5 amps 15 amps	9 amps N/A	900/408
5070122*	Yes	No	No	230 volts, 50 Hz, 10 amps 230 volts, 50 Hz, 10 amps	No plug No plug	9 amps** 10 amps	9 amps** N/A	900/408
50701209147	Yes	No	Yes	115 volts, 60 Hz, 20 amps 115 volts, 60 Hz, 15 amps	Yes Yes	5 amps 15 amps	9 amps N/A	900/408
50701229147*	Yes	No	Yes	230 volts, 50 Hz, 10 amps 230 volts, 50 Hz, 10 amps	No plug No plug	9 amps** 10 amps	9 amps** N/A	900/408
5080120	Yes	Yes	No	115 volts, 60 Hz, 20 amps 115 volts, 60 Hz, 15 amps	Yes Yes	5 amps 15 amps	9 amps N/A	900/408
5080122*	Yes	Yes	No	230 volts, 50 Hz, 10 amps 230 volts, 50 Hz, 10 amps	No plug No plug	9 amps** 10 amps	9 amps** N/A	900/408
50801209147	Yes	Yes	Yes	115 volts, 60 Hz, 20 amps 115 volts, 60 Hz, 15 amps	Yes Yes	5 amps 15 amps	9 amps N/A	900/408
50801229147*	Yes	Yes	Yes	230 volts, 50 Hz, 10 amps 230 volts, 50 Hz, 10 amps	No plug No plug	9 amps** 10 amps	9 amps** N/A	900/408

* International electrical configuration

** Total amperage for interior side receptacles and exterior receptacle combined

Protector® Double Controlled Atmosphere Glove Boxes

Dimensional Data

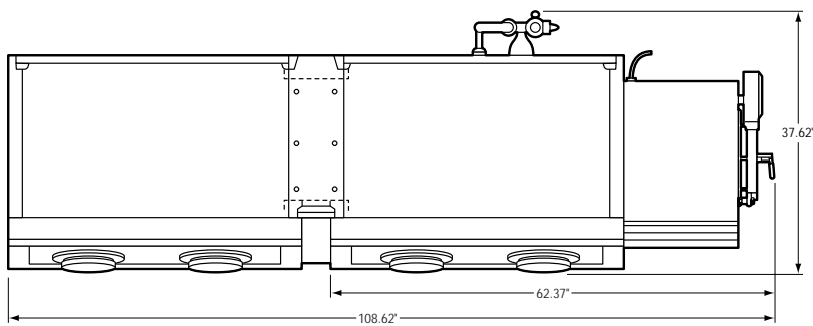

TOP

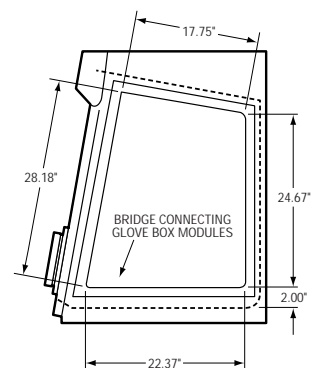

SECTION A-A

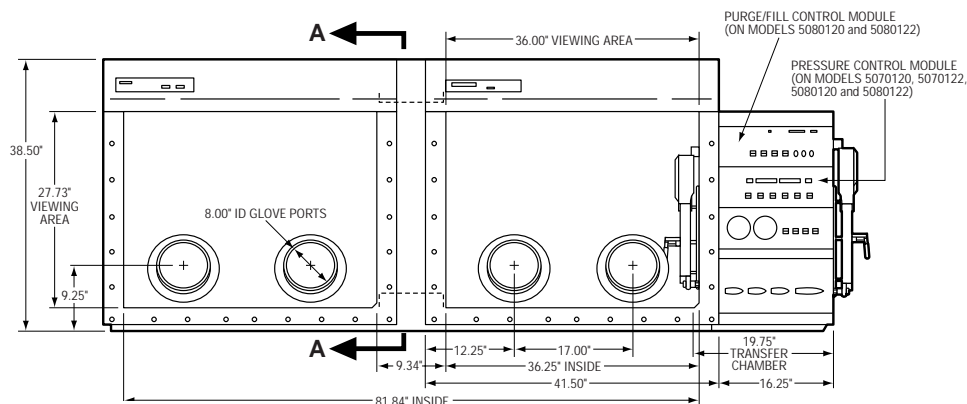

FRONT

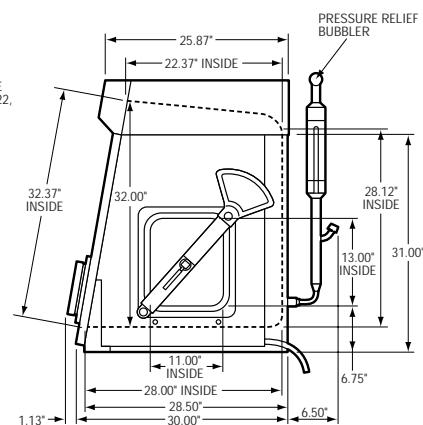

SIDE



Drying Train

Controlled Atmosphere Glove Boxes Accessories

Drying Trains

Provide a means for reducing the humidity within the glove box to less than 5 PPM (rated for achieving a dew point of -65° C). Include 1 CFM pump, stainless steel tubing to connect column to pump and 3-wire cord and plug. An on/off switch is located on the cord on 115 volt models. **3/8" OD copper tubing and two isolation valves are required.**

CATALOG NUMBER	ELECTRICAL REQUIREMENTS	NUMBER OF MOLECULAR SIEVE COLUMNS	SHIPPING WEIGHT LBS./KG
5061300	115 volts, 60 Hz, 3.15 amps	1	15/6.8
5061301	115 volts, 60 Hz, 3.15 amps	2**	17/7.7
5061302*	230 volts, 50 Hz, 1.55 amps	1	15/6.8
5061303*	230 volts, 50 Hz, 1.55 amps	2**	17/7.7

** One column is in use while the second column is regenerating.

5117000 Optional Second Column

A molecular sieve column and media (rated for achieving a dew point of -65° C). Provides immediate replacement column for Drying Train 5061300 or 5061302. Shipping weight 5 lbs. (2.3)

7837300 Molecular Sieve Replacement Media

For replacing spent media in Drying Train column. Provides two refills. Shipping weight 6 lbs. (2.7 kg)

5060500 Exterior Glove Port Cover

Seals glove port so that permeation through glove is reduced when glove box is not in use. Stainless steel with molded neoprene gasket. Adjustable tension knob with latching bar. Shipping weight 8 lbs. (3.6 kg)



Exterior Glove Port Cover #5060500

5060400 Interior Glove Port Cover

Quickly seals glove box should sudden leak occur due to glove damage. Stainless steel with molded rubber gasket and spring-loaded latches with adjustable closure knob. Shipping weight 8 lbs. (3.6 kg)



Interior Glove Port Cover #5060400

5061600 Interior Shelves

Provide shelf space across back wall of glove box interior. Three stainless steel storage shelves are attached to epoxy-coated steel upright supports. Shelves have adjustable height and measure 30" wide x 6" deep. Installation hardware and instructions included. Shipping weight 15 lbs. (6.8 kg)



Interior Shelves #5060400

Direct Drive Vacuum Pumps

108 liters/minute displacement capacity with gas ballast; ultimate vacuum (partial pressure) 1.3×10^{-4} mBar (0.1 micron).

CATALOG NUMBER	ELECTRICAL REQUIREMENTS	SHIPPING WEIGHT
7438700	115 volts, 50/60 Hz, 5.8 amps	47 lbs. (21 kg)
7438800	230 volts, 50/60 Hz, 2.9 amps with NEMA 6-15P plug	47 lbs. (21 kg)
7438900	230 volts, 50/60 Hz, 2.9 amps with reverse IEC plug	47 lbs. (21 kg)



Direct Drive Vacuum Pump #7438700

5060600 Vacuum Connection Kit (for vacuum only)

Kit includes components to connect vacuum pump to both the glove box and transfer chambers. Fits all Protector Glove Box models. Kit includes:

- Neoprene vacuum tubing, 3/4" ID x 3/8" wall x 3 feet long
 - Neoprene vacuum tubing, 3/4" ID x 3/8" wall x 1 foot long
 - Stainless steel reducing tee, 7/8" x 7/8" x 3/8" OD
 - Vacuum tubing, 5/16" ID x 3/16" wall x 3 feet long
 - Copper tubing, 3/8" OD x 12" long, to connect with the glove box exhaust Swagelok* fitting
- Shipping weight 10 lbs. (4.5 kg)

Vacuum and Gas Connection Kits

Kits includes components included in 5060600 Kit plus components to connect gas source to both the glove box and transfer chambers. Two kits are required for Protector Glove Boxes with AtmosPure Regenerative Drying Train. Shipping weight 15 lbs. (6.8 kg)

CATALOG NUMBER	FOR USE WITH MODEL SERIES:	COMPONENTS INCLUDED:
5060800	50600 and 50601	Vacuum Connection Kit 5060600 Copper tubing, 3/8" OD x 15 ft. Brass Tee, Swagelok, 3/8"
5060900	50700 and 50701	Same as 5060800 plus the following: Swagelok connector, 3/8" tube x 3/8" male pipe (2)
5061100	50800 and 50801	Same as 5060900 plus the following: Copper tube, 7/8" OD x 5" Swagelok connector, 7/8" tube x 3/4" male pipe

*Swagelok® is a registered trademark of Crawford Fitting Company

Multi-Hazard

Protector® Multi-Hazard Glove Boxes



Protector Multi-Hazard Glove Boxes provide a physical barrier to protect the operator from hazardous materials. Applications include work with gaseous or particulate hazardous substances used in pharmaceutical manufacturing, forensics and biochemistry. Non-bio-hazardous microorganisms, low-level radiochemicals, chemical carcinogens or asbestos may also be used within these glove boxes.

Inlet and exhaust HEPA filters trap particulate contaminants before they enter or leave the glove box. A second exhaust filter location allows for customization of the box with an additional HEPA filter for particulates or carbon for gaseous contaminants.

A pressure gauge monitors the condition of the filters. A built-in variable speed blower permits these boxes to be exhausted to the outside for an extra measure of protection.

Protector Multi-Hazard Glove Boxes are available with a variety of built-in options:

- Liners of one-piece molded fiberglass or stainless steel.
- Domestic 115 volts, 60 Hz operation or international 230 volts, 50 Hz operation.
- Double Stainless Steel Glove Boxes with twice the interior working width.
- Combination Glove Boxes for applications involving both hazardous chemicals and controlled atmospheres. See pages 24-26.

Full one year warranty on parts and labor.

Easy access circuit breakers on the back of the box provide over current protection to interior and exterior receptacle circuits.

One-piece molded fiberglass or stainless steel liner provides a smooth, durable surface that resists chemical corrosion and simplifies cleaning.

Laminated safety glass window, 3/8" thick, has 10° angle to minimize glare and help reduce operator fatigue. Large viewing area provides maximum visibility. Contact Labconco about polycarbonate windows.

Comfortable, 8" diameter, epoxy-coated aluminum glove ports are sealed with neoprene gaskets and stainless steel clamps. Ports are double-grooved so that gloves may be changed without disturbing the integrity of the box.

One-piece, molded neoprene gasket seals the glass to the liner and provides a leak-tight interior atmosphere.

Two interior electrical receptacles are separately controlled by individual switches on the control panel.

Neoprene gloves, size 9 3/4, 30" long, are included. For critical operations, butyl or Hypalon gloves are available.

ETL-listed. All 115 volt, 60 Hz models carry the ETL mark signifying that they are certified to UL 3101-1/61010-1 and CAN/CSA C22.2 No. 1010.1.

CE mark. All 230 volt, 50 Hz models conform to the CE (European Community) requirements for electrical safety and electromagnetic compatibility.



Features & Benefits

30-watt fluorescent lamp provides interior lighting and is easily accessible from outside of the chamber.

High efficiency polyester prefilter traps large particles, prolonging HEPA filter life.

Manual inlet control damper permits the operator to vary the internal negative pressure.

Inlet and outlet HEPA filters, 99.99% efficient on particulates 0.3 micron in diameter, prevent contaminants from entering or leaving the glove box chamber. Accessory HEPA and Carbon Filters allow customization to meet various application needs.

Built-in blower permits the box's interior atmosphere to be vented to the outside without the use of an external blower. A 3" square collar is provided for connection to the ducting system.

Large transfer chamber allows quick transfer of materials and equipment between the laboratory and the box.

Blower speed knob allows the operator to adjust the speed of the blower to vary the volume of airflow through the glove box while varying the internal negative pressure.

Pressure gauge enables the operator to monitor glove box pressures and inlet HEPA filter loading.



Control switches for fluorescent lamp, interior and exterior electrical receptacles are conveniently located on the control panel.

Epoxy-coated steel front and end panels complement laboratory furniture.

Space-saving inner and outer transfer chamber doors pivot upward, are counterbalanced and equipped with quick-latches for easy operation. Model Series 50600, 50700 and 50800 are made of 3/4" clear acrylic plastic for easy viewing. Model Series 50601, 50701 and 50801 are made of 11 gauge Type 304 stainless steel.

Protector® Multi-Hazard Glove Boxes

All models feature:

- Laminated safety glass window, 3/8" thick, with 10° angle and viewing area 36" w x 27.63" h.
- 12 gauge steel window frame with one-piece molded neoprene dual seal gasket.
- Two interior electrical receptacles with circuit breakers on the back of the box.
- One pair of neoprene gloves, size 9 3/4, 0.015 gauge, 30" long, with stainless steel clamps.
- Two 8" ID, epoxy-coated aluminum, double-grooved glove ports mounted 17" apart, with neoprene gaskets.
- 30-watt fluorescent lamp.
- Dry-powder epoxy-coated, 18 and 20 gauge steel exterior panels.
- High efficiency polyester prefilter.
- Manual inlet control damper to vary the internal negative pressure.
- Inlet and outlet HEPA filter, 99.99% efficient on particulates 0.3 micron in diameter.
- Built-in blower with blower speed control knob.
- Transfer chamber, interior dimensions 11" w x 20" d x 13" h, with counterbalanced inner and outer doors with quick-latches. Doors pivot upward to open.
- Control panel with glove box pressure analog gauge and control switches for fluorescent lamp and left and right interior receptacles.
- 3" square collar for connection to ductwork.

All models conform to the following regulations and standards:

- UL 3101-1/61010-1
- CAN/CSA C22.2 No. 1010.1
- CE Conformity Marking (230 volt models)

Fiberglass Models feature:

- One-piece molded fiberglass liner.
- Clear acrylic plastic inner and outer transfer chamber doors.

Stainless Steel Models feature:

- Type 304 stainless steel liner.
- Type 304 stainless steel inner and outer transfer chamber doors.

All models require (not included):

- **Base Stand.** See page 28.

Optional accessories for on-site installation include:

- **Exterior and Interior Glove Port Covers.** See page 27.
- **Interior Shelves.** See page 27.
- **Replacement HEPA Filter.** See page 27.
- **Carbon Exhaust Filter.** See page 27.
- **Additional Gloves, Sleeves and Hands.** See page 28.

Contact Labconco at **800-821-5525** or **816-333-8811** for ordering information on ultraviolet lights, RS-232 ports, left side doors, interior hose connections, additional electrical receptacles, polycarbonate windows, stainless steel transfer trays and mini-transfer chambers.



Protector® Multi-Hazard Glove Boxes

Ordering Information & Dimensional Data

CATALOG NUMBER	LINER MATERIAL	ELECTRICAL REQUIREMENTS	6' POWER CORD & PLUG	INTERIOR RECEPTACLES COMBINED RATING	SHIPPING WEIGHT LBS./KG
5065000	Fiberglass	115 volts, 60 Hz, 15 amps	Yes	9 amps	500/227
5065002*	Fiberglass	230 volts, 50 Hz, 10 amps	No plug	10 amps	500/227
5065500	Stainless Steel	115 volts, 60 Hz, 15 amps	Yes	9 amps	650/295
5065502*	Stainless Steel	230 volts, 50 Hz, 10 amps	No plug	10 amps	650/295

* International electrical configuration

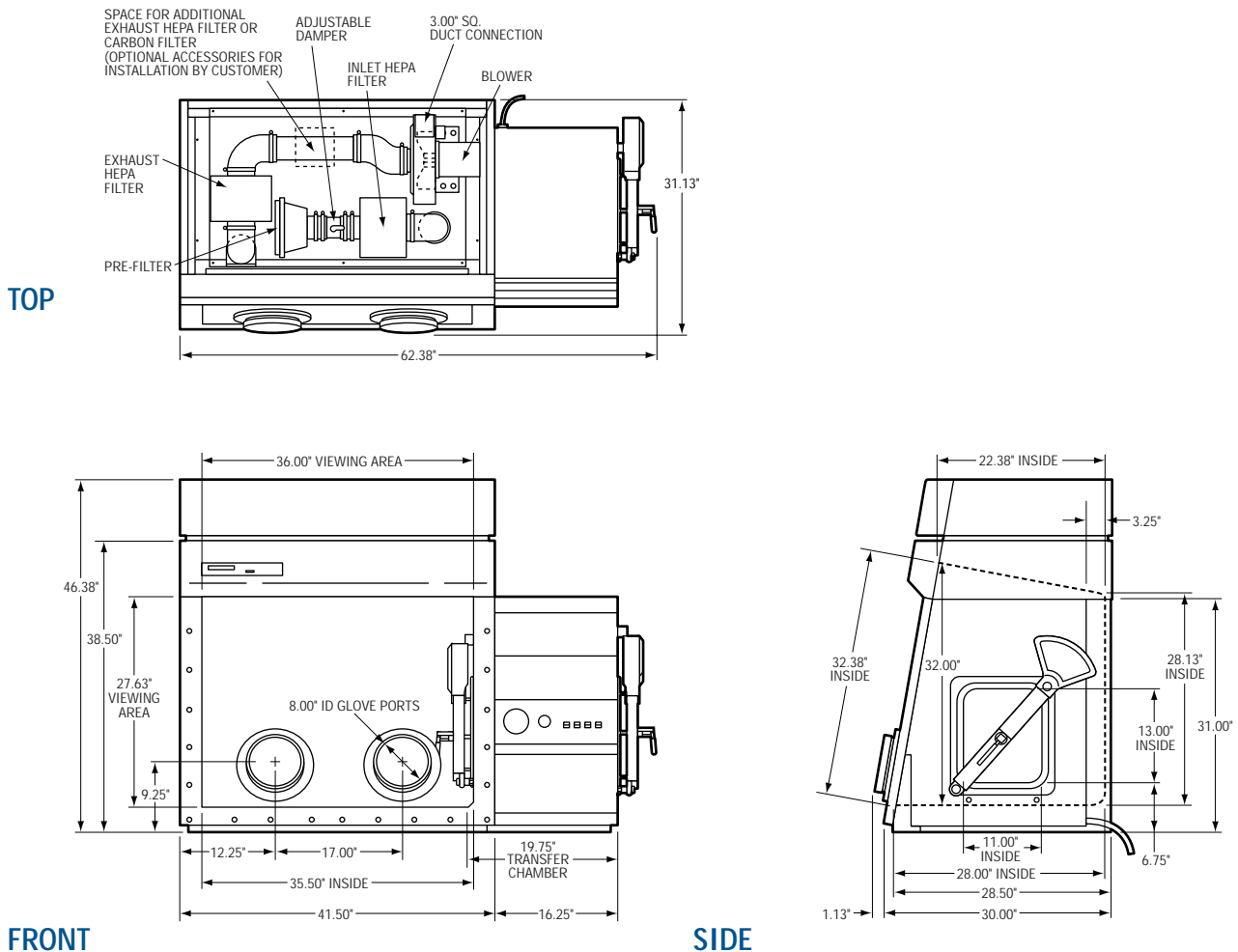

Protector® Double Multi-Hazard Glove Boxes



All models feature:

- Two Type 304 stainless steel liners connected by 9.34" wide, Type 304 stainless steel elevated bridge.
- Two laminated safety glass windows, 3/8" thick, each with 10° angle and viewing area 36" w x 27.63" h.
- Two 12 gauge steel window frame with one-piece molded neoprene dual seal gasket.
- Four interior electrical receptacles with circuit breakers on the back of the box: two located on either side and two located along the back wall of the elevated bridge.
- Two pairs of 8" ID, epoxy-coated aluminum, double-grooved glove ports mounted 17" apart, with neoprene gaskets.
- Two 30-watt fluorescent lamps.
- Dry-powder epoxy-coated, 18 and 20 gauge steel exterior panels.
- High efficiency polyester prefilter.
- Manual inlet control damper to vary the internal negative pressure.

- Inlet and outlet HEPA filter, 99.99% efficient on particulates 0.3 micron in diameter.
- Built-in blower with blower speed control knob.
- Transfer chamber, interior dimensions 11" w x 20" d x 13" h, with counterbalanced inner and outer Type 304 stainless steel doors with quick-latches. Doors pivot upward to open.
- Control panel with glove box pressure analog gauge and control switches for fluorescent lamp and left and right interior receptacles.
- 3" square collar for connection to ductwork.

All models conform to the following regulations and standards:

- UL 3101-1/61010-1
- CAN/CSA C22.2 No. 1010.1
- CE Conformity Marking (230 volt models)

All models require (not included):

- **Base Stand.** See page 28.

Optional accessories for on-site installation include:

- **Exterior and Interior Glove Port Covers.** See page 27.
- **Interior Shelves.** See page 27.
- **Replacement HEPA Filter.** See page 27.
- **Carbon Exhaust Filter.** See page 27.
- **Additional Gloves, Sleeves and Hands.** See page 28.

Contact Labconco at **800-821-5525** or **816-333-8811** for ordering information on ultraviolet lights, RS-232 ports, left side doors, interior hose connections, additional electrical receptacles, polycarbonate windows, stainless steel transfer trays and mini-transfer chambers.



Protector® Double Multi-Hazard Glove Boxes

Ordering Information & Dimensional Data

CATALOG NUMBER	ELECTRICAL REQUIREMENTS	(2) 6' POWER CORDS & PLUGS	RECEPTACLE COMBINED RATING	SHIPPING WEIGHT LBS./KG
5065520	115 volts, 60 Hz, 15 amps 115 volts, 60 Hz, 15 amps	Yes Yes	8 amps 15 amps	900/408
5065522*	230 volts, 50 Hz, 10 amps 230 volts, 50 Hz, 10 amps	No plug No plug	8 amps 10 amps	900/408

* International electrical configuration

SPACE FOR ADDITIONAL EXHAUST HEPA FILTER OR CARBON FILTER (OPTIONAL ACCESSORIES FOR INSTALLATION BY CUSTOMER)

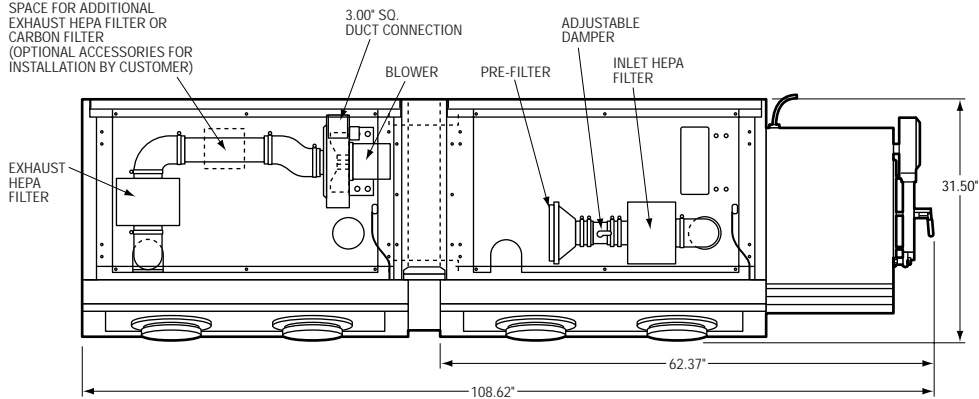

TOP

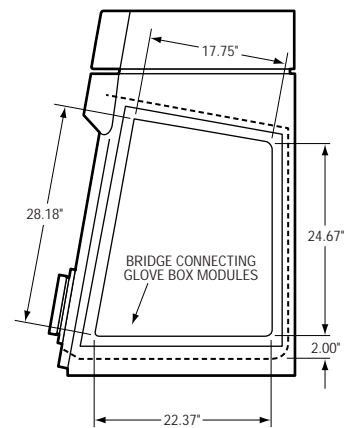

SECTION A-A

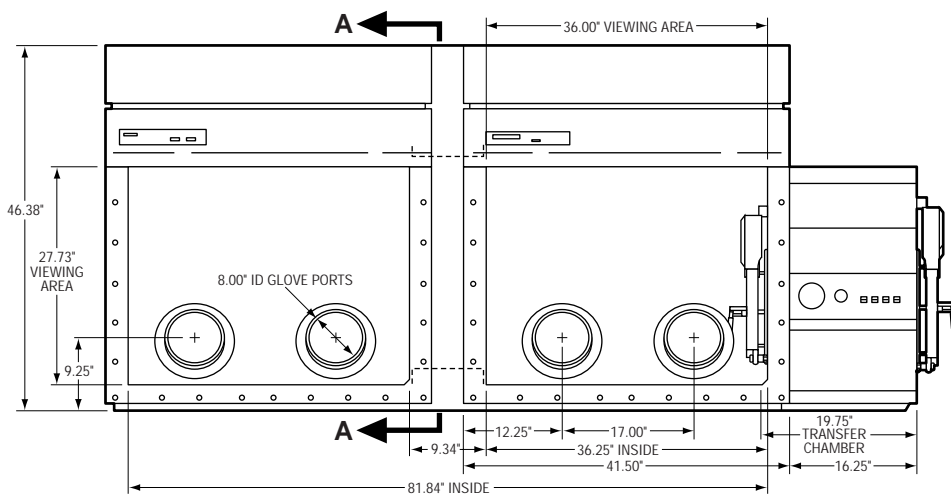

FRONT

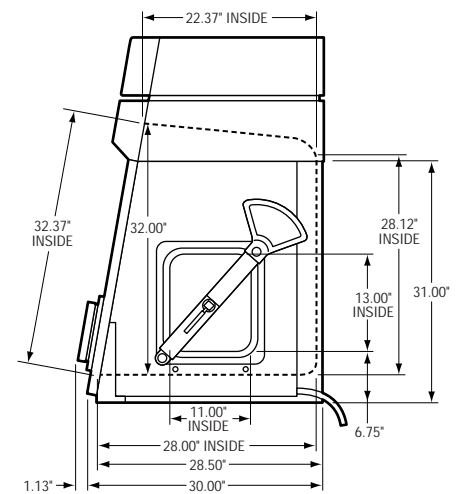

SIDE

Protector® Combination Glove Boxes



All models feature:

- Laminated safety glass window, 3/8" thick, with 10° angle and viewing area 36" w x 27.63" h.
- 12 gauge steel window frame with one-piece molded neoprene dual seal gasket.
- Two interior electrical receptacles with circuit breakers on the back of the box.
- Pressure relief bubbler. **Installation to back of box is required.**
- One pair of neoprene gloves, size 9 3/4, 0.015 gauge, 30" long, with stainless steel clamps.
- Two 8" ID, epoxy-coated aluminum, double-grooved glove ports mounted 17" apart, with neoprene gaskets.
- 30-watt fluorescent lamp.
- Dry-powder epoxy-coated, 18 and 20 gauge steel exterior panels.
- No detectable leaks greater than 1×10^{-6} cc/sec (31.55 cc/year) when factory-tested while pressurized with helium at 5" water gauge.
- Transfer chamber, interior dimensions 11" w x 20" d x 13" h, with counterbalanced inner and outer doors with quick-latches. Doors pivot upward to open.
- Control panel with glove box and transfer chamber pressure analog gauges; four valves to manually control gas input and exhaust of glove box and transfer chamber; and control switches for fluorescent lamp, left and right interior receptacles and rear exterior receptacle.
- 3/8" OD glove box gas inlet and outlet (vacuum) connections, 3/8" OD transfer chamber inlet connection and 7/8" OD transfer chamber outlet (vacuum) connection.
- Two internal valves to convert the glove box from a flow-through filtered box to a leak-tight inert atmosphere box.
- High efficiency polyester prefilter.
- Manual inlet control damper to vary the internal negative pressure.
- Inlet and outlet HEPA filter, 99.99% efficient on particulates 0.3 micron in diameter.
- Built-in blower with blower speed control knob.
- 3" square collar for connection to ductwork.

All models conform to the following regulations and standards:

- UL 3101-1/61010-1
- CAN/CSA C22.2 No. 1010.1
- CE Conformity Marking (230 volt models)

Fiberglass Models feature:

- One-piece molded fiberglass liner.
- Clear acrylic plastic inner and outer transfer chamber doors.

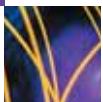

Stainless Steel Models feature:

- Type 304 stainless steel liner.
- Type 304 stainless steel inner and outer transfer chamber doors.

Models with Pressure Control Module and Foot Pedal feature:

- Pressure Control Module that automatically monitors and controls glove box pressure.
- Switches for high/low pressure limits and alarm reset.
- LED display to indicate range setting within -6" to +6" water gauge and actual pressure.
- Audible/visual alarm that alerts when pressure is outside of set range.
- Alarm reset to mute the audible alarm.
- Foot pedal control with 8' cable for hands-free adjustment of glove box pressure.

Models with Purge/Fill Control Module feature:

- Purge/Fill Control Module to automatically control evacuation and backfill of transfer chamber.
- Switches for selection of number of purge/fill sequences, level of vacuum achieved at each purge cycle, and choice of backfill source.
- LED display to indicate number of purge/fill cycles selected and countdown of cycles, status of cycle (purging or filling), and source of purge/fill cycles.

All models require (not included):

- **Base Stand.** See page 28.
- **Vacuum Pump.** See page 17.
- **Inert Gas.** Contact your compressed gas supplier.
- **Vacuum and Gas Connection.** See page 17.

Optional accessories for on-site installation include:

- **Drying Trains.** See page 17.
- **Exterior and Interior Glove Port Covers.** See page 17.
- **Interior Shelves.** See page 17.
- **Replacement HEPA Filter.** See page 27.
- **Carbon Exhaust Filter.** See page 27.
- **Neoprene, Butyl and Hypalon Gloves.** See page 28.

Contact Labconco at **800-821-5525** or **816-333-8811** for ordering information on double glove boxes, RS-232 ports, moisture/oxygen monitors, left side doors, interior hose connections, additional electrical receptacles, polycarbonate windows, stainless steel transfer trays and mini transfer chambers.

Protector® Combination Glove Boxes

Ordering Information

CATALOG NUMBER	LINER MATERIAL	PRESSURE CONTROL MODULE & FOOT PEDAL	PURGE/FILL CONTROL MODULE	ELECTRICAL REQUIREMENTS	6' POWER CORD & PLUG	INTERIOR RECEPTACLES COMBINED RATING	EXTERIOR RECEPTACLE RATING	SHIPPING WEIGHT LBS./KG
50600009158	Fiberglass	No	No	115 volts, 60 Hz, 20 amps	Yes	6 amps	9 amps	530/240
50600029158*	Fiberglass	No	No	230 volts, 50 Hz, 10 amps	No plug	4 amps	6 amps	530/240
50601009158	Stainless Steel	No	No	115 volts, 60 Hz, 20 amps	Yes	6 amps	9 amps	680/308
50601029158*	Stainless Steel	No	No	230 volts, 50 Hz, 10 amps	No plug	4 amps	6 amps	680/308
50700009158	Fiberglass	Yes	No	115 volts, 60 Hz, 20 amps	Yes	6 amps	9 amps	533/242
50700029158*	Fiberglass	Yes	No	230 volts, 50 Hz, 10 amps	No plug	4 amps	6 amps	533/242
50701009158	Stainless Steel	Yes	No	115 volts, 60 Hz, 20 amps	Yes	6 amps	9 amps	683/310
50701029158*	Stainless Steel	Yes	No	230 volts, 50 Hz, 10 amps	No plug	4 amps	6 amps	683/310
50800009158	Fiberglass	Yes	Yes	115 volts, 60 Hz, 20 amps	Yes	6 amps	9 amps	535/243
50800029158*	Fiberglass	Yes	Yes	230 volts, 50 Hz, 10 amps	No plug	4 amps	6 amps	535/243
50801009158	Stainless Steel	Yes	Yes	115 volts, 60 Hz, 20 amps	Yes	6 amps	9 amps	685/311
50801029158*	Stainless Steel	Yes	Yes	230 volts, 50 Hz, 10 amps	No plug	4 amps	6 amps	685/311

* International electrical configuration

Protector® Combination Glove Boxes

Dimensional Data

TOP

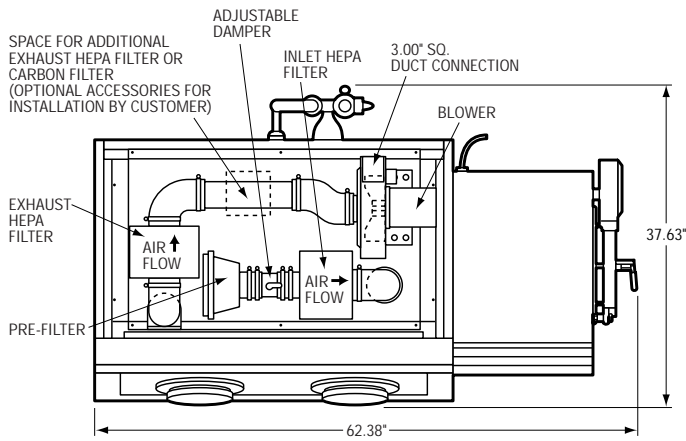

FRONT

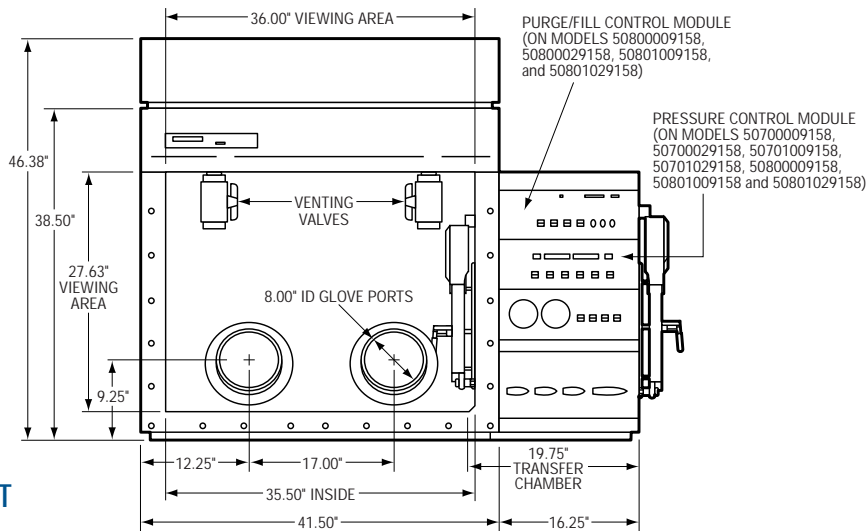

SIDE

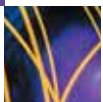
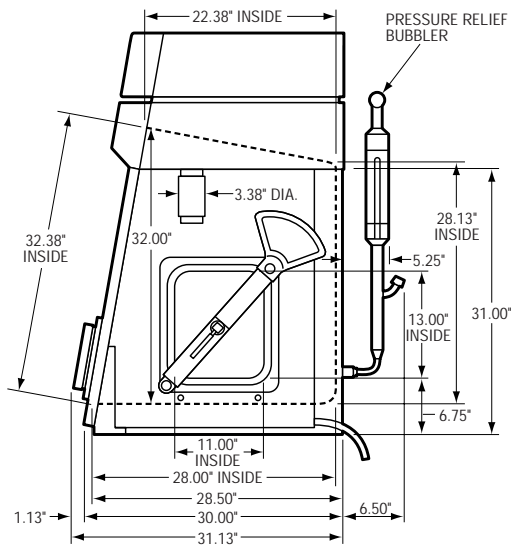

Protector® Multi-Hazard Glove Boxes

Accessories

Recommended Second Exhaust Filter Options

APPLICATION/MATERIAL	HEPA	CARBON
Carcinogenic Materials		X
Biological Materials*	X	
Radiochemicals - particulate	X	
Radiochemicals - gaseous		X

* Non-biohazardous

5065100 HEPA Inlet or Exhaust Filter

Replacement inlet or exhaust filter or optional second exhaust filter for removal of particulate contaminants. Filter is 99.99% efficient on particles 0.3 micron in diameter. Shipping weight 6 lbs. (2.7 kg)

5065300 Carbon Exhaust Filter

Optional second exhaust filter for removal of gaseous organic contaminants in low-level radioisotope or chemical carcinogen applications. Shipping weight 10 lbs. (4.5 kg)

5060500 Exterior Glove Port Cover

Seals glove port so that permeation through glove is reduced when glove box is not in use. Stainless steel with molded neoprene gasket. Adjustable tension knob with latching bar. Shipping weight 8 lbs. (3.6 kg)

5060400 Interior Glove Port Cover

Quickly seals glove box should sudden leak occur due to glove damage. Stainless steel with molded rubber gasket and spring-loaded latches with adjustable closure knob. Shipping weight 8 lbs. (3.6 kg)

5061600 Interior Shelves

Provide shelf space across back wall of glove box interior. Three stainless steel storage shelves are attached to epoxy-coated steel upright supports. Shelves have adjustable height and measure 30" wide x 6" deep. Installation hardware and instructions included. Shipping weight 15 lbs. (6.8 kg)

*Swagelok® is a registered trademark of Crawford Fitting Company.



Interior Glove Port Cover #5060400



Exterior Glove Port Cover #5060500



Interior Shelves #5060400



Carbon Exhaust Filter 295065300



HEPA Inlet or Exhaust Filter #5065100



Glove Box Mobile Base Stand #5062000



Glove Box Base Stand #5062001

Glove Box Base Stands

Epoxy-coated welded steel base with black phenolic laminate work surface. Height is adjustable between 30" and 36". Lower shelf provides convenient space for peripheral equipment and accessories. Furnished with 5-inch diameter swivel casters with locking brakes. Work surface dimensions: 60" W x 31" D x 1.13" thick.

CATALOG	DESCRIPTION	SHIPPING WEIGHT
5062000	Glove Box Mobile Base Stand with 5" diameter swivel casters with locking brakes	300 lbs. (136 kg)
5062001	Glove Box Base Stand with adjustable leveling feet	300 lbs. (136 kg)
5062020	Double Glove Box Mobile Base Stand with 5" diameter swivel casters with locking brakes	400 lbs. (181 kg)

Gloves, Sleeves and Hands



CATALOG NUMBER	U/M	GAUGE	SIZE	SHIPPING WEIGHT LBS./KG
A 5005500 5005600	Product Description: Neoprene Gloves. One piece, seamless. With O-rings. Pair Pair	0.015 0.015	8 1/2 9 3/4	3/1.4 3/1.4
B 5005501 5005601	Product Description: Butyl Gloves. One piece, seamless. Provide high impermeability to water vapor, gases and toxic chemicals. Resistant to oxygenated solvents and most oxidizing chemicals. With O-rings. Pair Pair	0.015 0.015	8 1/2 9 3/4	3/1.4 3/1.4
C 5005502 5005602	Product Description: Hypalon Gloves. One piece, seamless. Resistant to abrasion, ozone and oxidizing chemicals. With O-rings. Pair Pair	0.015 0.015	8 1/2 9 3/4	3/1.4 3/1.4
D 5005800	Product Description: Neoprene Straight Sleeves. For use with any of the hands listed below. With O-rings and springs. Pair			3/1.4
E 5005900	Product Description: Neoprene Accordion Sleeves. For use with any of the hands listed below. With O-rings and springs. Pair			3/1.4
F 5006000 5006100 5033100	Product Description: Neoprene Hands Only. Lightweight, embossed with firm-hold finish. For use with either Straight or Accordion Sleeves. (Pkg. of 12 pair) (Pkg. of 12 pair) (Pkg. of 12 pair)	0.017 0.017 0.017	7 1/2 9 10	2/0.9 2/0.9 2/0.9
G 5006200 5006300	Product Description: Latex Hands Only. White, surgical-type. For use with either Straight or Accordion Sleeves. (Pkg. of 12 pair) (Pkg. of 12 pair)	0.009 0.009	7 9	2/0.9 2/0.9
H 5005603	Product Description: Latex Gloves. One piece, seamless. For use when dexterity is needed. Limited protection. With O-rings. Pair	0.015	9 3/4	3/1.4

Contact Labconco at **800-821-5525** or **816-333-8811** for more information about these quality products for your laboratory.



Fume Hoods,
Carbon-Filtered
Enclosures and Blowers



HEPA-Filtered
Safety Cabinets,
Enclosures and Clean
Benches



Laboratory
Animal Research
Enclosures



Water
Purification Systems



Glassware Washers



Freeze Dry Systems



Centrifugal
Concentrators and
Cold Traps



Multiple Sample
Evaporation Systems



Agricultural
Chemistry Products



Laboratory
Carts and Benches



Digital
Chloridometers



Density Gradient
Fractionators



Vacuum Desiccators



Blood Drawing Chairs



Labconco Corporation
8811 Prospect Avenue
Kansas City, Missouri 64132-2696
800-821-5525
816-333-8811
FAX: 816-363-0130
E-Mail: labconco@labconco.com
Home Page: www.labconco.com

© 2005 by Labconco Corporation
Printed in the U.S.A.
Product design subject to change without notice.

